

INSTALLATION INSTRUCTIONS

APPLICATION: 2007-08 Dodge Nitro, Nitro SLT, Nitro R/T

WARNING

Although this hitch is designed to safely tow its rated load, we recommend that you consult your vehicle owner's manual for possible manufacturer's recommendations or limitations. Always follow the manufacturer's installation instructions and always install on the specified vehicle. Before installing hitch, check that the attachment points are in good condition.

Failure to follow these guidelines will void warranty. Any modifications to this hitch will void warranty.

CLASS III

WEIGHT CARRYING HITCH CAPACITY

**3500 LBS. MAXIMUM TRAILER WEIGHT
350 LBS. MAXIMUM TONGUE WEIGHT**

WEIGHT DISTRIBUTING HITCH CAPACITY

**5000 LBS. MAXIMUM TRAILER WEIGHT
500 LBS. MAXIMUM TONGUE WEIGHT**

Trailer brakes are recommended for towing loads in excess of 1500 lbs.

COMPLETE PARTS LIST

Part	Description	Quantity
1.	Hitch Assembly	(1)
<i>HARDWARE KIT #112512</i>		
2.	237204 12mm x 1.75 x 40mm Hex Bolt Class 10.9	(6)
3.	373005 1/2 Conical Toothed Washer	(6)
4.	112513 Instruction Sheet	(1)
<i>T Connector</i>		
5.	30002039 T Connector Assembly	(1)

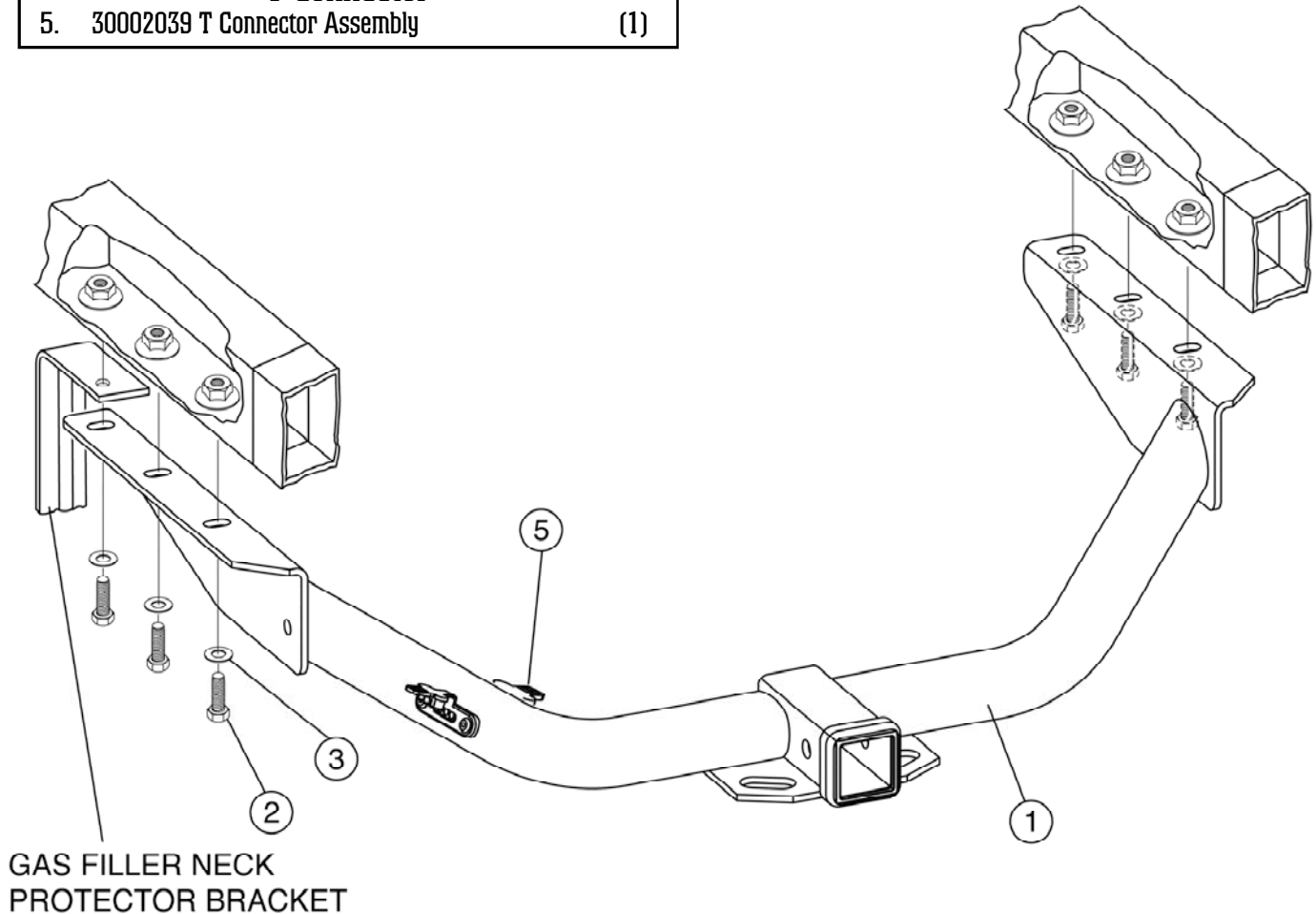

1. ***Read instructions thoroughly before beginning.***

2. Raise the rear hatch door and remove the tail light housings from each side of the rear of the vehicle (Fig. 1A).



Fig. 1A

3. Beginning with the left (drivers) side tail light assembly, remove the gray wiring harness connector from the back of the housing by squeezing the locking tabs. Inspect the connector for dirt & debris and clean if necessary (Fig. 2).



Fig. 2

Caution: Take care not to damage the locking tabs.

4. Plug the harness ends containing the yellow wires into the tail light housing and separated connector from step 3. Press firmly, ensuring the locking tabs engage.

5. Route the harness ends with the green wire across the top of the bumper to the right (passenger) side of the vehicle.

6. Repeat steps 3 & 4 for the right side using the connectors with the green wires.

7. Locate a clean accessible mounting location on the vehicle near the wiring harness ends within reach of the white wire and grounding eyelet and drill a 7/64" hole.

Caution: Take care not to drill through the body or any exposed surface.

8. Mount the White wire using the ground screw and eyelet provided.

9. Push the 4-flat trailer connector down through the left (driver's) side tail light housing and out under the vehicle.

Hitch Installation

1. Remove the tow hook from bottom of driver's side vehicle frame. Discard the attaching bolts and tow hook. Remove the bolt holding gas filler neck protector bracket to frame. See illustration 1.

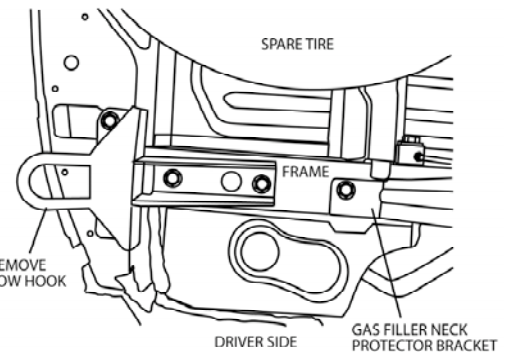

2. Position hitch assembly up against the bottom surface of each vehicle frame. Align holes in hitch frame brackets with holes going through vehicle frames. On driver's side, the existing gas filler neck protector bracket will get sandwiched between the frame and hitch bracket.

3. Secure hitch to frame with 12mm x 1.75 x 40mm Hex Bolt Class 10.9 #2, and 1/2 Conical Toothed Washer #3, 3 per side.

4. Tighten the hex bolts to 75 ft. lbs. torque. Failure to tighten bolts as described may result in fastener loss or failure.

5. Plug the remaining connector of the installed harness T-Connector #5 into the mating connector on the inward side of the hitch once installed. Press the connectors firmly together, ensuring that the locking tabs engage.

6. Re-install the tail light housings to their original positions, taking care not to pinch or damage any wires.

7. Confirm correct operation of the 4-Flat connector by using a test light or a properly equipped trailer.

8. Secure any loose wires under the vehicle using cable ties.

WARNING: When lowering spare tire, use caution to avoid damaging T-Connector.

WARNING: Use only a 5/8" diameter hitch pin with locking device to secure a ball mount in this receiver.

WARNING: Be sure to check the hitch pin and hair pin for positive locking placement before towing trailer.

NOTE: When hitch is not being used, remove ball mount from receiver and place the receiver cover into receiver opening.

NOTE: Some states require a clear view of license plates. Remove trailer ball and/or ball mount when not in use if it restricts view.

For information regarding the installation of this product, go to: www.towingsupport.com
or Email us at: tech@towingsupport.com or Call our Technical Support Team at: 1-800-344-3230

This product complies with regulation V-5, C.S.A Standard D-264 and safety requirements for connecting devices and towing systems of the State of New York