

INSTALLATION INSTRUCTIONS

Rev. 2

MODEL NO. 88010

Hardware Kit #112549

APPLICATION: 2007-08 Saturn Outlook (With factory tow package)
 2008-09 Buick Enclave (With factory tow package)
 2007-08 GMC Acadia (With factory tow package)

WARNING

Although this hitch is designed to safely tow its rated load, we recommend that you consult your vehicle owner's manual for possible manufacturer's recommendations or limitations. Always follow the manufacturer's installation instructions and always install on the specified vehicle. Before installing hitch, check that the attachment points are in good condition.

Failure to follow these guidelines will void warranty. Any modifications to this hitch will void warranty.

CLASS III

WEIGHT CARRYING HITCH CAPACITY

**4,000 LBS. MAXIMUM TRAILER WEIGHT
 400 LBS. MAXIMUM TONGUE WEIGHT**

WEIGHT DISTRIBUTING HITCH CAPACITY

**5,000 LBS. MAXIMUM TRAILER WEIGHT
 500 LBS. MAXIMUM TONGUE WEIGHT**

Trailer brakes are recommended for
 towing loads in excess of 1500 lbs.

COMPLETE PARTS LIST

Part	Description	Quantity
1.	Receiver Assembly	(1)
<u>HARDWARE KIT #112549</u>		
2.	237204 M12-1/75 x 40 Hex Bolt Cl. 10.9	(6)
3.	373005 1/2 Conical Washer	(6)
4.	112550 Instruction Sheet	(1)
<u>T CONNECTOR</u>		
5.	30002041 T Connector Assembly	(1)

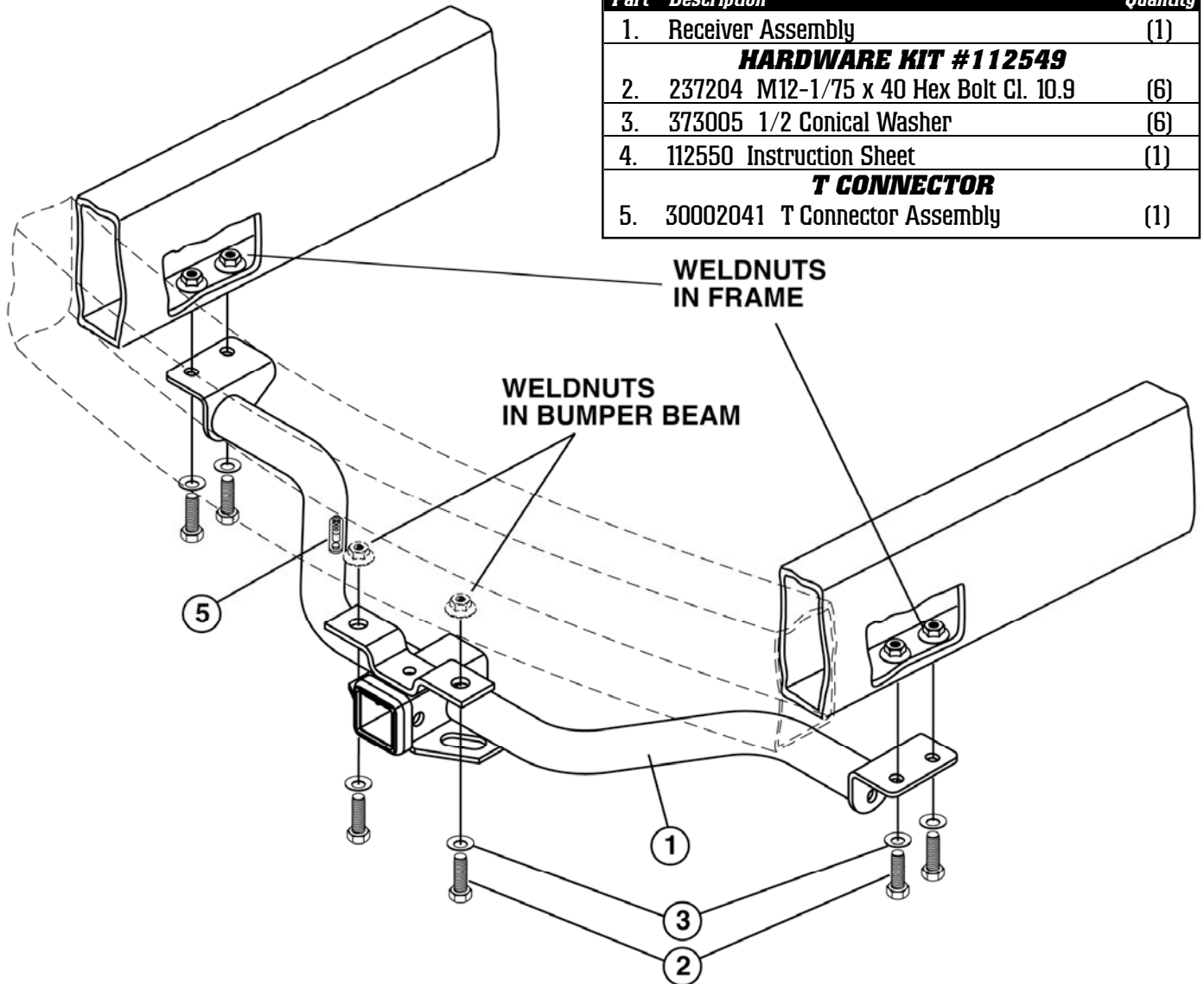

1. ***Read instructions thoroughly before beginning.***

2. Locate the vehicles factory OEM trailer light wiring harness. On vehicles equipped with a factory 7-way connector, the harness will be attached to the hitch on the left (driver's) side at the rear of the vehicle. For vehicles without factory tow wiring connectors, the harness will be located under the vehicle along the left (driver's) side frame rail near a cross member (Fig. 1). The harness will have a connector similar to that on the end of the Hitch Wiring Harness.

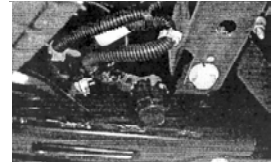

Fig. 1

3. Separate the 7-Way connector from the vehicle wiring harness (If Present). Carefully remove the grey locking tab (Fig. 3) and gently pull the connector and harness apart while holding down on the connector locking latch taking care not to damage the locking tabs.



Fig. 2

4. For vehicle without a factory 7-way connector, remove and save the protective cap covering the vehicle harness connector taking care not to damage the locking tabs. Clean the connector if necessary.

5. Insert the long Hitch Wiring Harness socket into the factory harness connector. Firmly press the ends together until the locking tabs engage. Position the protective cap removed in step 3 on the shorter socket end of the Hitch Wiring Harness, pressing firmly in place until the locking tabs engage.

Hitch Installation

1. Detach rubber muffler hanger from muffler hook. This will allow the muffler to drop down and allow clearance for the hitch installation. The muffler will go back up in the original location after hitch is installed.
2. On bumper skin, remove cutout at yoke location to allow receiver assembly to fit snug under bumper.
3. Lower the muffler enough to allow hitch assembly to fit up to mounting points on vehicle frame.
4. Attach hitch assembly frame brackets to existing weldnuts in vehicle frame using M12-1/75 x 40 Hex Bolt Cl. 10.9 #2 and 1/2 Conical Washer #3 supplied in hardware kit.
Attach hitch assembly yoke at center to existing weldnuts in vehicle frame using M12-1/75 x 40 Hex Bolt Cl. 10.9 #2 and 1/2 Conical Washer #3 supplied in hardware kit.
5. Tighten the Hex Bolts #2 to 92 ft. lbs. torque. Failure to tighten bolts as described may result in fastener loss or failure.
6. Plug the remaining connector of the installed harness into the mating connector on the inward side of the hitch once installed. Press the connectors firmly together, ensuring that the locking tabs engage.
7. Confirm correct operation of the 4-Flat connector by using a test light or a properly equipped trailer.
10. Re-install the muffler by hanging the muffler hook back onto the rubber hanger.

WARNING: Use only a 5/8" diameter hitch pin with locking device to secure a ball mount in this receiver.

WARNING: Be sure to check the hitch pin and hair pin for positive locking placement before towing trailer.

NOTE: Some states require a clear view of license plates. Remove trailer ball and/or ball mount when not in use if it restricts view.

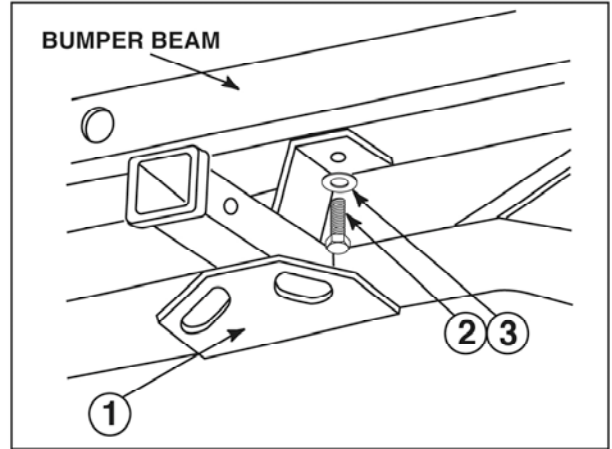
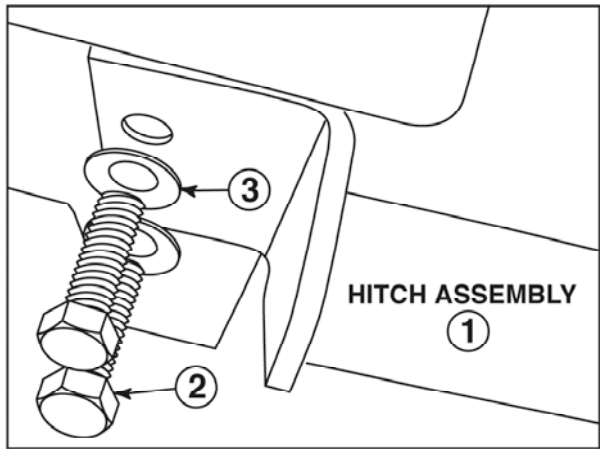
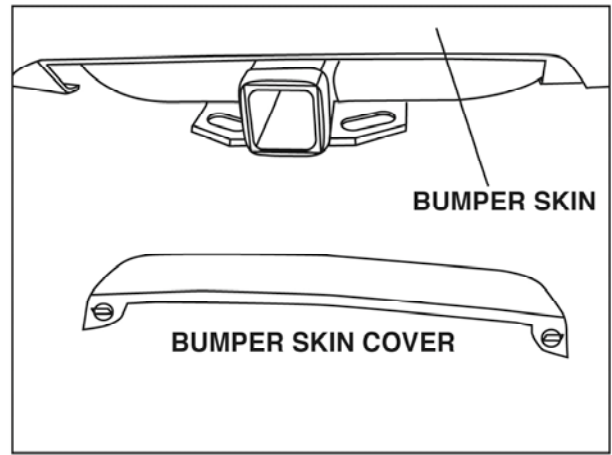
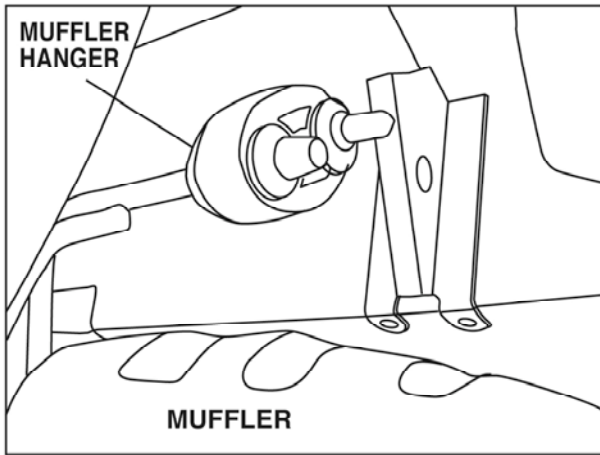

For information regarding the installation of this product, go to: www.towingsupport.com
or Email us at: tech@towingsupport.com or Call our Technical Support Team at: 1-800-344-3230

This product complies with regulation V-5, C.S.A Standard D-264 and safety requirements for connecting devices
and towing systems of the State of New York