

November 2007

# **INSTALLATION, OPERATION & MAINTENANCE INSTRUCTIONS**

## **MODEL NO. 70530**

**Please be sure that this document is given to the end user of this product.  
This contains many important items relating to the proper usage of this product.**

### **IMPORTANT NOTICE**

This is an RV 5th wheel hitch. Use of this hitch for COMMERCIAL trailer towing will limit the hitches warranty to 1 year

### **COMPLETE PARTS LIST**

<b>Part</b>	<b>Description</b>	
1.	3845-02 Head Assembly	(1)
2.	2648-05 Handle Assembly	(1)
3.	3852-09 Cross Member Assembly	(1)
4.	2687-01 Upright Assembly	(1)
5.	3590-02 1/4" x 1-1/2" Hex Screw	(1)
6.	2278-05 1/4" Flange Locknut	(1)
7.	2953-03 1/2" x 4-1/2" Hex Bolt	(4)
8.	1880-03 1/2" Lockwasher	(4)
9.	1862-03 1/2" Hex Nut	(4)
10.	1557-01 1/2" x 4-1/2" Rail Hitch Pin	(4)
11.	1335-03 Hair Pin	(6)
12.	1083-04 1/2" x 2-7/8" Hitch Pin	(2)
13.	3848-04 Latch Handle Grip	(1)
14.	3670-02 Shim	(4)
15.	3853-07 Safety Pin Assembly	(1)

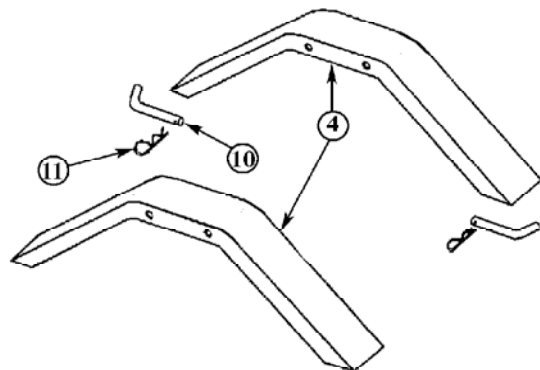
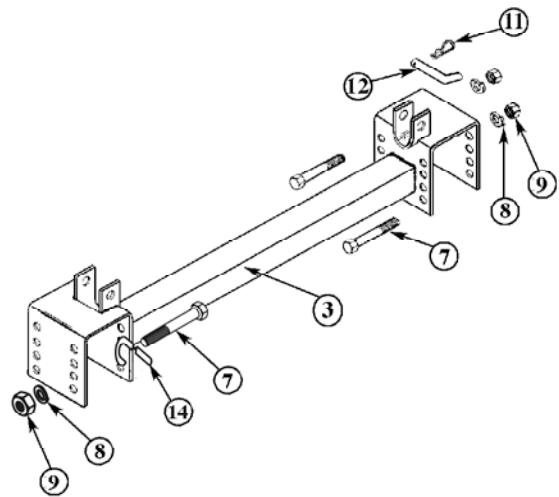
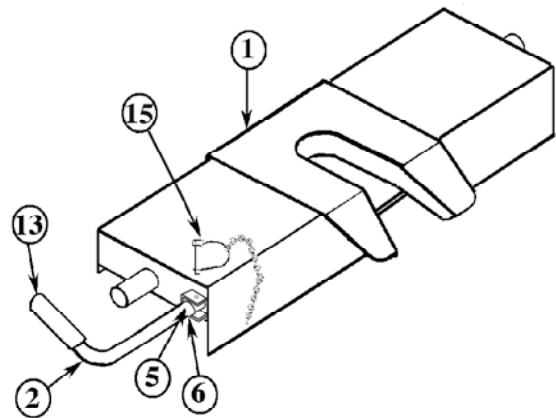

**15,000 Maximum Trailer Weight  
3,750 Vertical Load Weight**

## **BEFORE BEGINNING INSTALLATION:**

Be sure that the loaded trailer weight does not exceed 15,000 lbs. or the vertical load rating does not exceed 3,750 lbs.

Be sure that the weight of the loaded trailer does not exceed the truck manufacturers trailer towing or payload capacities.

Use only a 2" king pin with this 5th wheel hitch.

The installed position of the 5th wheel hitch is critical relative to the distance from the cab so that the front of the trailer does not make contact with the cab when turning. On most applications, the distance from the back of the truck cab to the center of the trailer king pin should be 6" greater than 1/2 the width of the trailer.

## **INSTALLATION INSTRUCTIONS**

1. The 5th wheel hitch is packaged in two cartons. The 7045 or 7055 bed rail kit, is a separate item and is not included with the hitch. Unpack all parts and compare them with the illustrated packing list and installation instructions.
2. Place the two bed rails across the truck bed between the wheel wells. Position the uprights #4 between the bed rails so that the tab in the base upright will fit into the slots in the ends of the bed rails. Secure the uprights in place with the rail hitch pins #10 and hair pins #11.
3. Go to the bed rail and custom install bracket kit instructions, to install the bed rails.
4. Determine the height of the head assembly. This height should be set so that there is 5"-6" minimum clearance between the bottom of the trailer overhang and the top of the truck box. More clearance may be needed if travel over uneven roads is expected. Bolt the cross member assembly #3 between the uprights at the correct height. Tighten all 1/2" bolts to 75 ft. lbs. torque. If pin placement in base rail is tight, it may be necessary to place one of the 1/2 Flatwashers #13 between the cross member and the upright at each attachment bolt. See Illustration A.
5. Place the head assembly into the U-brackets at each end of cross member #3. Secure with hitch pin #12 and hair pin #11 as illustrated. Check the height of the hitch head to be certain that there is the required 5" to 6" minimum clearance between the bottom of the trailer overhang and the top of the truck box. Make any adjustments as needed to obtain this clearance.
6. Attach the latch handle assembly #2 on the rod located on the left side of the hitch head assembly #1. Align holes in handle and rod. Bolt in place with 1/4" fasteners #5 and #6 as illustrated.

**You are now ready to hook up your 5th wheel trailer.  
See the "Trailer Hook Up Instructions" on the following pages.**

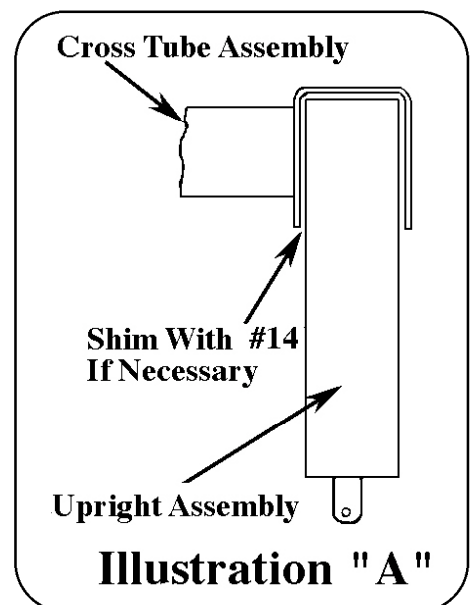

## **TRAILER HOOK UP INSTRUCTIONS**

### **FOLLOW THESE INSTRUCTIONS FOR EACH HOOK UP**

1. Before connecting trailer to the hitch, the safety pin must be removed from the locking bracket and handle. Be sure that the handle has moved completely inward and the jaw is closed. If handle is out, jaw is open. To close, push the handle rearward and inward. The spring tension should pull the handle into the closed position.
2. Adjust the trailer height so that the king pin plate is approximately 1/2" below the 5th wheel plate on the hitch. The ramps leading into the king pin box will pick up the trailer as the truck backs under the trailer king pin.
3. Lower the tailgate on the truck. Be sure that the trailer wheels are properly blocked, front and rear.
4. Carefully back the truck under the trailer so that the 2" king pin will engage fully into the hitch head and actuate the lock jaw. The jaw will have pivoted around the king pin into the closed position.
- 4a. Look at the pointer located on the forward surface of the hitch head assembly. When it is exposed and visible, beyond the housing, the king pin is fully seated.

- 4b. Look at the jaw to be certain it is closed and that the handle is in as far as it will go. Pivot the locking bracket down into groove in handle. Insert the safety pin through holes in bracket, handle and tab below handle. Lock in place. See Illustrations below. Failure to follow these procedures could result in the hitch coming open and dropping trailer.

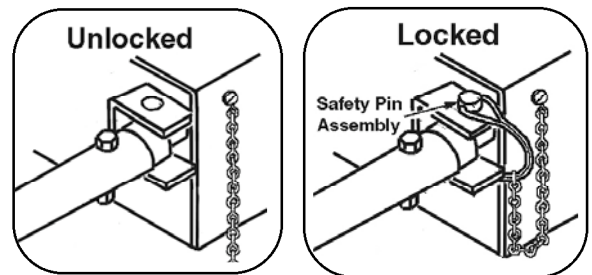

5. Connect the wiring harness from the trailer to the truck. Be sure that all cables are routed in such a way that they can not become tangled with hitch assembly. Check trailer brakes and lights for correct operation. DO NOT raise the trailer jacks at this time.
6. With trailer jacks still down, apply trailer brakes alone and try to slowly pull forward with truck. This will double check that the king pin is locked into the 5th wheel assembly. The trailer brakes should keep the truck from moving forward if the hitch is locked correctly.
7. Raise the trailer jacks to their retracted storage position. Remove the blocks from the front and rear of the trailer wheels.
8. Check between the bottom of the trailer overhang and the top of the truck bed for adequate clearance.

## **TRAILER DISCONNECT INSTRUCTIONS**

1. Block the front and rear of the trailer wheels. Disconnect the wiring harness from the truck.
2. Set the trailer jacks so that most, but not all, of the trailer load is off the hitch.
3. Remove the safety pin from the locking bracket and handle on the hitch head assembly. Pull the handle out and forward until it drops into the notch. This locks the jaw into the open position.
4. Drive the truck slowly forward and out from under the trailer.
5. Reset handle into the closed position.

# SERVICE AND MAINTENANCE INSTRUCTIONS

Lubricate all points on 5th wheel assembly as noted on illustrations below. Use heavy wheel bearing grease at all locations.

Keep internal jaw locking parts in head assembly well lubricated with a heavy wheel bearing grease for continued smooth operation.

The latch handle should be lubricated so that it will continue to move smoothly and easily.

Check for tightness of all assembly bolts. Re-tighten if necessary. Tighten 1/2-13 bolts to 75 ft. lbs. torque and 3/4-10 bolts to 260 ft. lbs. torque.

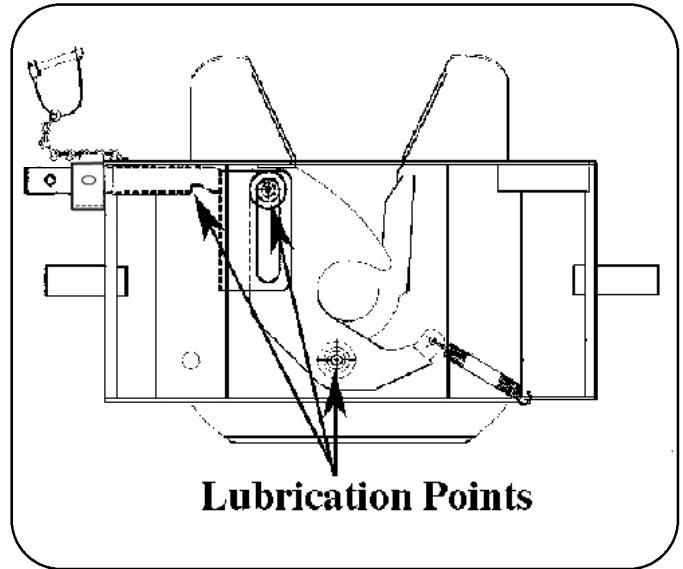

**\*Periodically check the moving parts inside the head assembly. If any one of them shows wear or damage, it should be replaced. Follow the illustrations below to replace parts in the head assembly.**

<i>REPLACEMENT PARTS LIST</i>			
<i>Refer to Illustrations for locations of parts</i>			
<b>Part</b>	<b>Description</b>		<b>Quantity</b>
A.	3826-05 Latching Jaw Assembly	(1)	
B.	1501-06 Short Extension Spring	(1)	
C.	3829-03 Latch handle Assembly	(1)	
D.	1835-03 1/2 x 1-1/4 Hex Bolt	(2)	
E.	3491-02 1/2 Internal Lockwasher	(1)	
F.	1846-09 1/2 Flatwasher	(1)	
G.	3279-06 Slide Bracket Bushing	(1)	

<b>Part</b>	<b>Description</b>		<b>Quantity</b>
H.	3833-07 Indicator Cross Bar	(1)	
I.	3482-08 Torsion Spring	(1)	
J.	4147-03 3/8 x 7/8 Hex Bolt	(1)	
K.	2300-07 3/8 Conical Washer	(1)	
L.	1828-03 1/2 Flange Locknut	(2)	
M.	3626-03 1/2 x 1-1/4 Hex Bolt	(1)	
N.	3853-07 Safety Pin Assembly	(1)	

