

INSTALLATION INSTRUCTIONS

Rev. 5

MODEL NO. 55133

APPLICATION: 2008-Current Ford F250, F350 & F450 SD P/U

NOTE: Works with 70580-71880 Xtreme Duty Base Rails.

COMPLETE PARTS LIST

#	Part	Qty
1.	Right Frame Bracket Weld Assembly	(1)
2.	Left Frame Bracket Weld Assembly	(1)
3.	1/4" Bed Spacer	(4)
4.	3/4" Bed Spacer (Traditional Rails Only)	(4)
5.	Frame Spacer 1/2" Thick	(2)
6.	9/16"-12 x 1-3/4" Hex Bolt	(2)
7.	9/16" Flatwasher	(4)
8.	9/16" Lockwasher	(2)
9.	9/16"-12 Hex Nut	(2)

#	Part	Qty
10.	5/8"-11 x 3-1/2" Hex Bolt	(4)
11.	5/8" Flatwasher	(4)
12.	5/8" Lockwasher	(4)
13.	5/8"-11 Tapped Plate	(4)
14.	3/4"-10 x 2-1/2" Hex Bolt	(2)
15.	3/4" Flatwasher	(4)
16.	3/4" Lockwasher	(2)
17.	3/4"-10 Hex Nut	(2)

8' & 6-1/2' Bed Applications
(Not Recommended for 5-1/2' Bed)

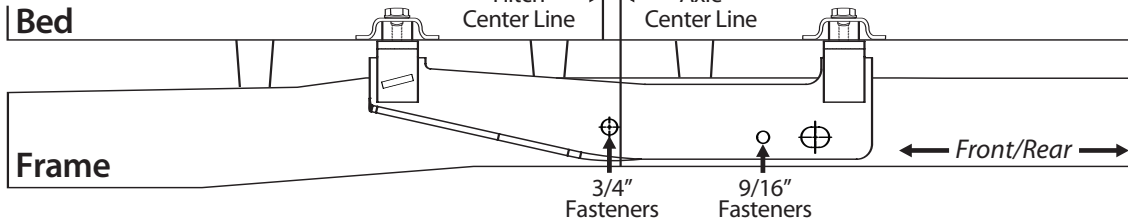

Truck Bed

Once The Rear Rail ① Position Is Established, Use Hitch Uprights To Locate The Front Rail ② Location.

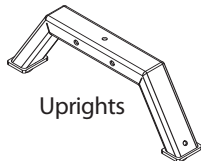

← Front/Rear →

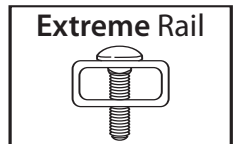
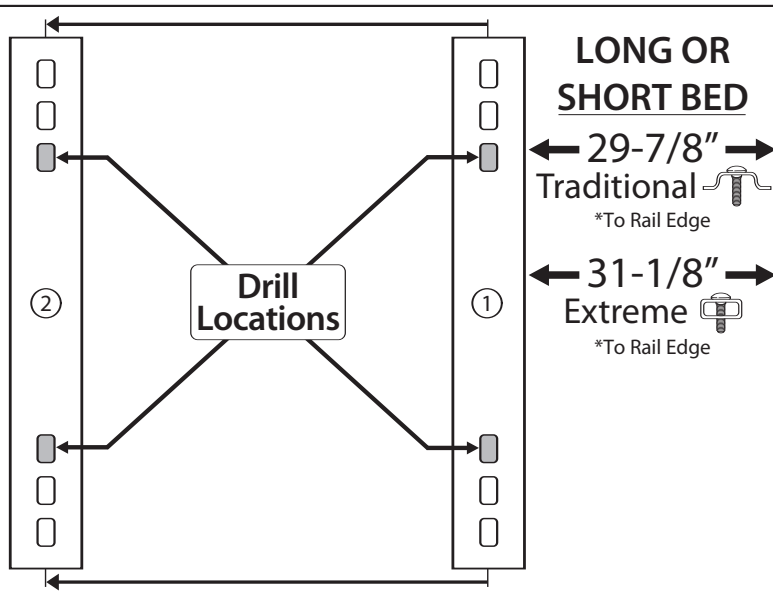

From bolt center to rail edge, the Traditional Rail is 1-1/4" wider than the Extreme Rail.

- CAUTION:** Do not install mounting rails over plastic bed liners. Plastic bed liners must be cut out of the way. Rails may be installed on spray in liners.
- NOTE:** Consult spray liner installer for recommended curing time.

1. Position the right and left frame brackets #1 and #2 against their appropriate side of truck frame as shown on Illustration 1.

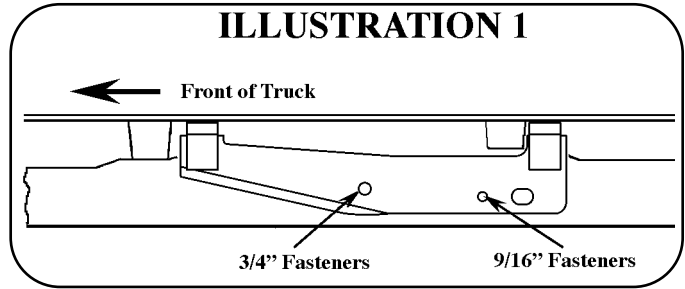

2. Place a 3/4" hex bolt #14 and 3/4" washer #15 through the truck frame slot at the center attachment point in frame bracket. Place a 1/2" thick spacer plate #5 on bolt between the truck frame and the frame bracket, as shown on Illustration 3. Bolt in place with a 3/4" flatwasher #15, 3/4" lockwasher #16 and 3/4" hex nut #17.

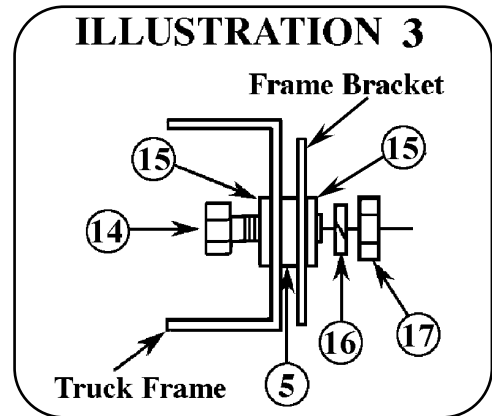

3. Use remaining 9/16" hole in bracket #1 & 2 as guide and drill 9/16" hole into the truck frame. Bolt frame brackets to frame with 9/16" fasteners as shown on Illustration 4. Do not tighten fasteners at this time.

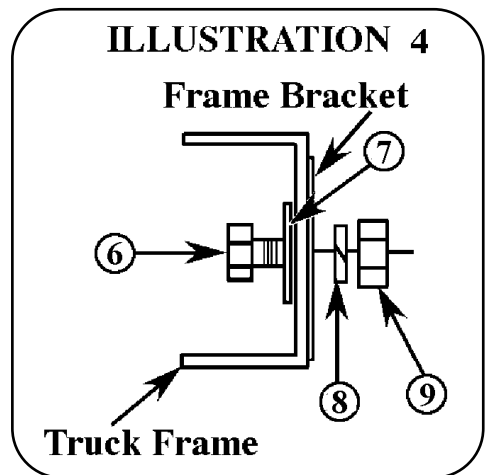

4. Place the two bed rails across the truck bed between the wheel wells. Position the 5th wheel uprights between the bed rails so that the tabs in the base of each upright will fit into the slots in the ends of the bed rails. Secure the uprights in place with the rail hitch pins and hair pins supplied with the 5th wheel installation kit. Securely attach 5th wheel cross member to uprights.
5. Position the bed rail assembly in truck bed as shown on the layout illustration on the front page of this instruction sheet. When hitch is correctly positioned in the bed and the bed rails are parallel, mark four attachment points on the truck bed using the 5/8" square holes indicated on the layout Illustration on Page 1 of this document.
6. Check below the bed before drilling holes to see that all wiring, brake lines or other obstructions are moved out of the way and will not be contacted by the drill. Drill a 1/4" pilot hole through bed floor at each previously marked location. Check to see that these holes line up with installed frame bracket mounting tabs. Adjust hole location as needed. Move the hitch assembly out of the way and drill four 5/8" diameter attachment holes down through the bed at the previously marked points.

7. Reposition the bed rails in the bed so that the square 5/8" hole in the end of each rail is lined up over the drilled holes. Place a 3/4" thick spacer block #4 under ends of each bed rail, in line with the drilled holes. See Illustration 5.

ILLUSTRATION 5

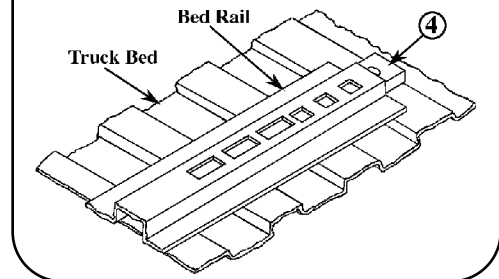

8. If the bed corrugation above the frame bracket is UP, leaving a space above the frame bracket, place a spacer plate #3 in this location as shown on Illustration 6. If the corrugation is DOWN, at this location, place a spacer plate #3 in the bed, under the base rail as shown on Illustration 6a. Bolt parts loosely in place as shown on Illustration 7.

ILLUSTRATION 6

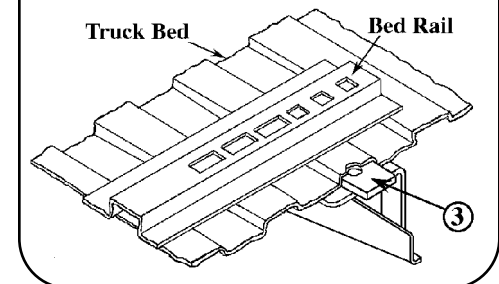

9. Tighten all 1/4" attachment bolts to 8 ft. lbs. torque, all 1/2" attachment bolts to 75 ft. lbs. torque, all 9/16" attachment bolts to 110 ft. lbs. torque and the 3/4" bolts to 260 ft. lbs. torque. Failure to tighten bolts as described may result in fastener loss or failure.

10. Tighten each 5/8" bed rail attachment bolt to 150 ft. lbs. torque. Failure to tighten bolts as described may result in fastener loss or failure.

ILLUSTRATION 6a

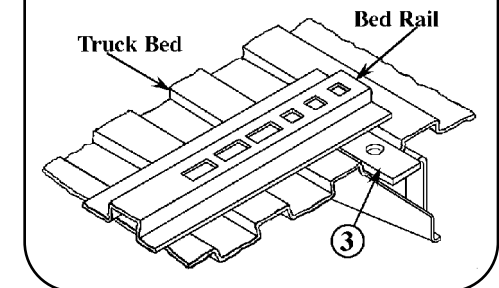
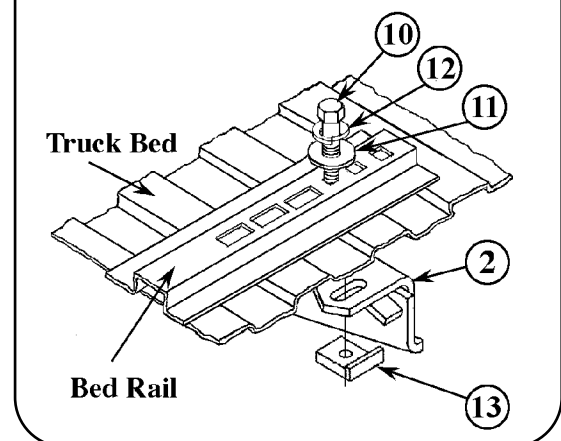

ILLUSTRATION 7



For information regarding the installation of this product, go to: www.vtowing.com
or Email us at: techsupport@vtowing.com or Call our Technical Support Team at: 1-800-344-3230

This product complies with regulation V-5, C.S.A Standard D-264 and safety requirements for connecting devices and towing systems of the State of New York

55133